

# OP55 – light hydraulic door-opener

the OP55 hydraulic door opener ensures quick and silent opening of inward opening non-armoured doors and also outward by acting as a spreader. The handle with a contactor to action the door-opener offers a good hand hold.



## OP55



The OP55 hydraulic door opener ensures quick and silent opening of inward opening non-armoured doors and also outward by acting as a spreader.

To work the OP55 needs a LIBERVIT hydraulic unit or manual pump.

The start contactor is used to deploy the door-opener\*. On releasing the contactor, the tool stops and automatically retracts.

The OP55 is delivered in a transport bag. It can also be delivered on option in a PELICASE.

\* when used with a manual pump the OP55 does not automatically retract and you will not have to press on the start contactor.

### TECHNICAL CHARACTERISTICS

light hydraulic door-opener	ref. OP55	
jack thrust	59 kN	
jack's stroke	140 mm - 5.5 inch	
dimensions	325 x 95 x 232 mm - 13 x 4 x 9 inch	
weight	5.3 kg - 11 lbs	
available colours	dark grey or olive green	
transport bag	yes, ref. ST/OP55	
PELICASE transport case	on option, ref. VDT/OP55 (LIBERVIT BLACKline)	on option, ref. VLD/OP55 (LIBERVIT Défense)
hydraulic coupling cap	on option, ref. BF	

# OP71- light hydraulic door-opener

ensures the opening of inward and outward opening doors silently and quickly as well as some ships' waterproof doors.



## OP71 - OP71P



The OP71 and OP71P hydraulic door opener ensure quick and silent opening of inward opening non-armoured doors and also outward by acting as a spreader.

To work the tool needs a LIBERVIT hydraulic unit or manual pump.

The start contactor is used to deploy the door-opener\*. On releasing the contactor, the tool stops and automatically retracts.

The OP71 and OP71P are delivered in a transport bag, they can also be delivered on option in a PELICASE.

\* when used with a manual pump the tools do not automatically retract and you will not have to press on the start contactor. On option a handle can be added for a better tool hold.

(\*tool not self-sufficient needs to be used with a hydraulic power unit or manual pump)

### TECHNICAL CHARACTERISTICS

	ref. OP71	réf. OP71P
light hydraulic door-opener	ref. OP71	réf. OP71P
1st stage thrust	71 kN	71 kN
2nd stage thrust	28 kN	28 kN
Jack's stroke	262 mm - 10 inch	262 mm - 10 inch
1st stage's stroke	151.5 mm - 6 inch	151.5 mm - 6 inch
2nd stage's stroke	110.5 mm - 4.5 inch	110.5 mm - 4.5 inch
dimensions	350 x 120 x 120 mm - 14 x 4.5 x 4.5 inch	363 x 260 x 117 mm - 14 x 10 x 4.5 inch
weight	5.9 kg - 12 lbs	6.2 kg - 13.5 lbs
transport bag	oui, réf. ST/OP7	oui, réf. ST/OP7P
OP71 grip handle	on option, ref. POP7	
PELICASE transport case.	on option, ref. VDT/OP7 ou VLD/OP7	on option, ref. VDT/OP7P ou VLD/OP7P
coupling cap	on option, ref. BF	on option, ref. BF





# HR7- mid-range hydraulic door-opener

designed to open PVC or wooden doors, single or multi-locks opening inward.



## HR7



Designed to open PVC or wooden doors, single or multi-locks opening inward, the HR7 is placed horizontally between the door's vertical frames. A handle on the jack gives a better grip. It has an exclusive telescopic rod system with a "Extend" quick-lock and it can be adjusted in length to reduce installation time in front of the door. For power supply, the HR7 requires either one of the LIBERVIT hydraulic power units or a LIBERVIT hand pump. Two control switches on the tool activate the HR7 jacks.  
(\*tool not self-sufficient needs to be used with a hydraulic power unit or manual pump)





# HR7- mid-range hydraulic door-opener

TECHNICAL CHARACTERISTICS		
mid-range hydraulic door-opener	ref. HR7	
horizontal jack's thrust	56 kN	
retracted horizontal jack length	670 mm - 26 inch	
deployed horizontal jack length	942 mm - 37 inch	
horizontal jack & R36 extension length	1292 mm - 4.2 ft	
pushing jack 1st stage thrust	71 kN	
pushing jack 2nd stage thrust	28kN	
pushing jack 1st stage stroke	175 mm - 7 inch	
pushing jack 2nd stage stroke	113 mm - 4.5 inch	
total pushing jack stroke	288 mm - 11 inch	
horizontal jack handle	yes	
start switches	yes, qty 2	
available colours	dark grey, black or olive green	
dimensions	670 x 470 x 100 mm - 26.5 x 18.5 x 4 inch	
door-opener and plate pair weight PP/HR7	13.6 kg - 29.5 lbs	
delivered with 3 plates' pair	yes, ref. PP/HR7, PR/HR7, PRL/HR7	
PP/HR7 plate dimensions	74.7 x 72 x 33.5 mm - 3 x 2.5 x 1.2 inch	
Plate weight	520 g - 1.15 lbs	
PR/HR7 plate dimensions	74.7 x 72 x 51.13 mm - 3 x 2.5 x 2 inch	
Plate weight	580 g - 1.28 lbs	
PRL/HR7 plate dimensions	74.7 x 92 x 51.13 mm - 3 x 3.5 x 2 inch	
Plate weight	700 g - 1.54 lbs	
delivered with extension	yes, ref. HR80	
dimensions	110 x 72 x 74.7 mm - 4 x 3 x 3 inch	
weight	1 kg - 2.2 lbs	
delivered with extension	yes, ref. R36	
retracted HR7 length with extension	265 mm - 10.4 inch	
deployed HR7 length with extension	347.5 mm - 13.7 inch	
dimensions	288.5 x 72.5 x 74.75 mm - 11.4 x 2.8 x 3 inch	
weight	1.6 kg - 3.5 lbs	
delivered with tape measure	yes, ref. L3M	
tape length	3 m - 10 ft	
tape width	16 mm - 0.5 inch	
magnetic	yes	
self-locking	yes	
dimensions	70 x 60 x 30 mm - 3 x 2.5 x 1 inch	
weight	11 g - 0.5 oz	
delivered in PELICASE transport case	yes, ref. VDT/HR7 (LIBERVIT BLACKline)	ref. VDT/HR7 (LIBERVIT Défense)
available colours	black	olive green
dimensions	628 x 498 x 303 mm - 25 x 20 x 12 inch	625 x 500 x 218 mm - 24 x 19 x 8 inch
weight empty	10.4 kg - 23 lbs	6.5 kg - 14 lbs
weight loaded	28.5 kg - 62 lbs	24.6 kg - 54 lbs



HR80 extension



L3M tape measure



×2 plates, ref: PP/HR7



×2 plates, ref: PR/HR7



×2 plates, ref: PRL/HR7



# HR7 DIFFERENT POSITIONS' DIMENSIONS

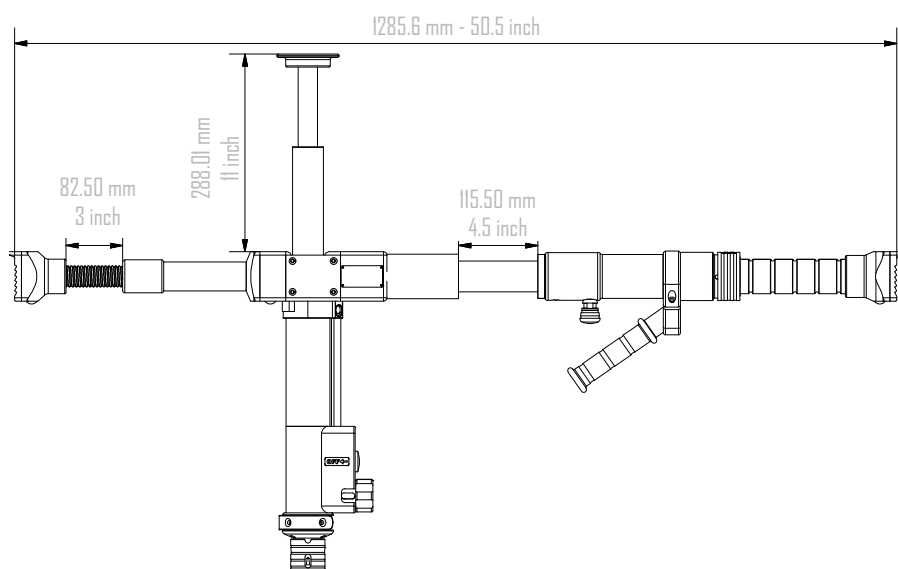
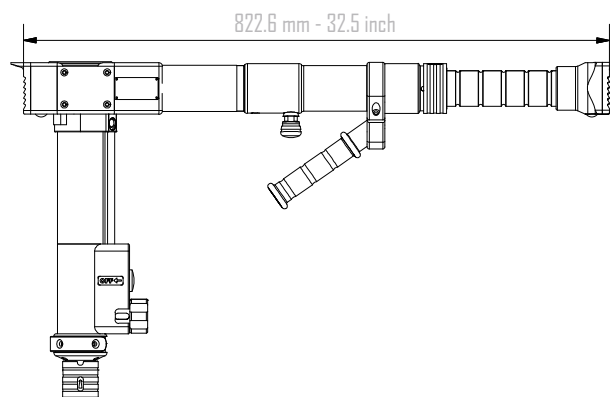
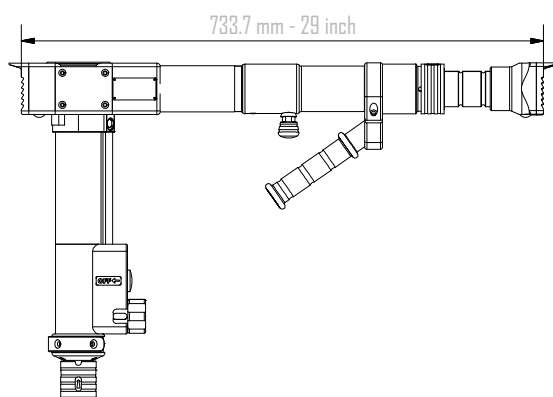
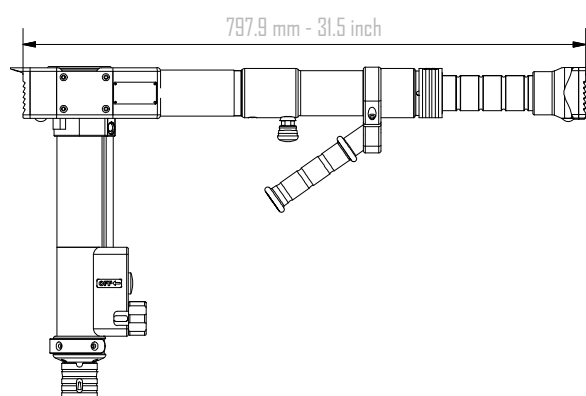
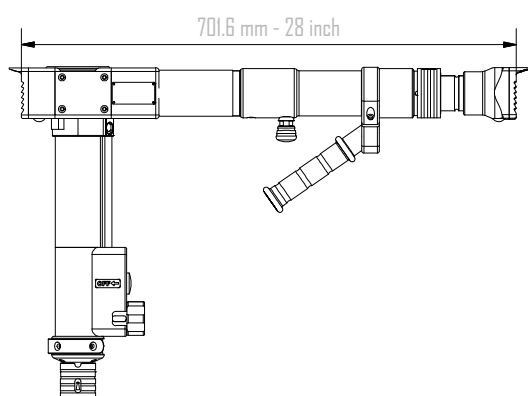
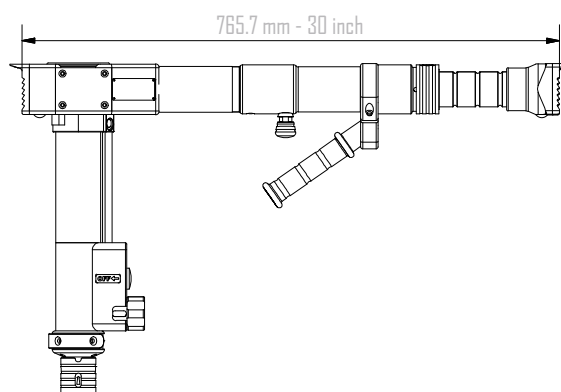
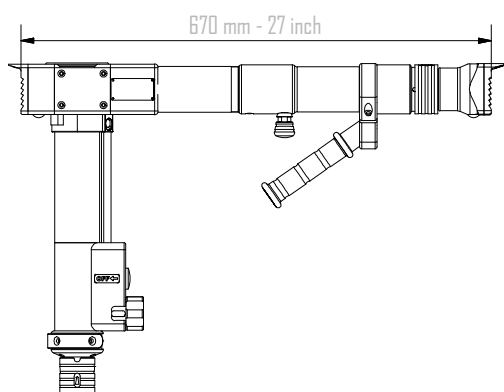

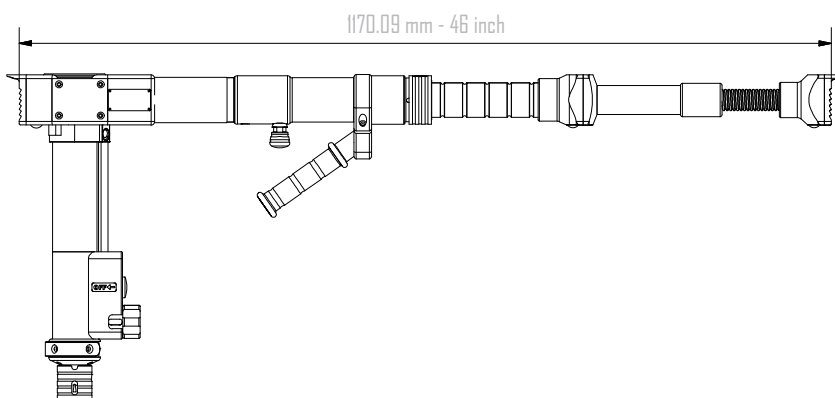
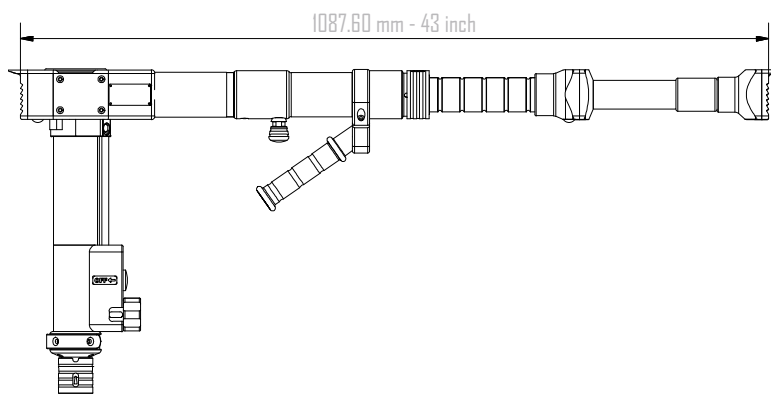
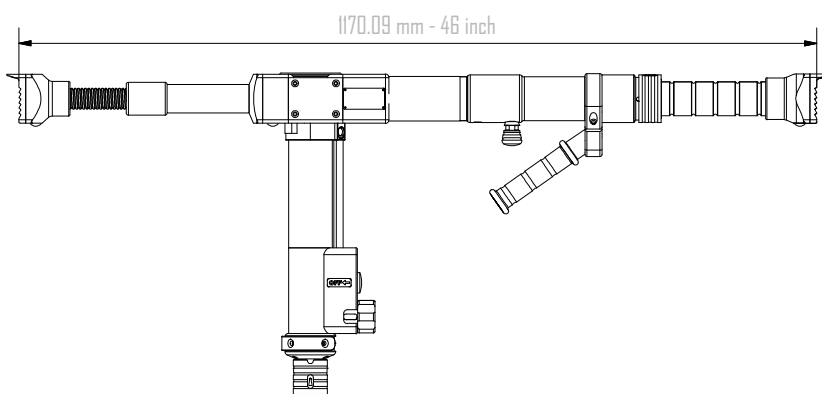
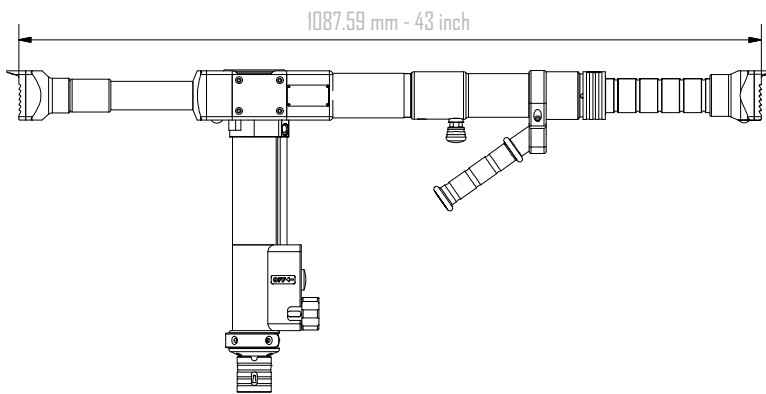

## ACCESSORIES - BF & BM- PROTECTION CAP

protection cap BM



protection cap BF

protection cap  
colour  
dimensions  
weight

ref. BF  
black  
40 mm x Ø60 mm - 1.5 inch x Ø2.5 inch  
60 g - 0.13 lbs

protection cap  
colour  
dimensions  
weight

ref. BM  
black  
40 mm x Ø60 mm - 1.5 inch x Ø2.5 inch  
60 g - 0.13 lbs

The protection caps BF (female) and BM (male) protect your LIBERVIT hydraulic tools coupling from shocks and dust. When buying the HR7 the protection cap is an option.

## ACCESSORIES - PX/HR7 extensions

HR7 extension case  
Delivered in transport case  
Extensions included  
Case dimension  
Weight empty  
Weight loaded

ref. PX/HR7  
yes, ref VDT/PXHR7, case PELICASE  
ref. HR80, HR150, HR200  
406 x 330 x 174 mm - 16 x 13 x 7 inch  
2.6 kg - 5.7 lbs  
10 kg - 22 lbs



extension  
material  
dimensions  
weight

ref. HR80  
black anodized aluminium  
110 x 72 x 74.7 mm - 4 x 3 x 3 inch  
1 kg - 2.2 lbs

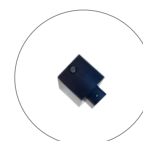

extension  
material  
dimensions  
weight

ref. HR150  
black anodized aluminium  
180 x 72 x 74.7 mm - 7 x 3 x 3 inch  
1.1 kg - 2.4 lbs



extension  
material  
dimensions  
weight

ref. HR200  
black anodized aluminium  
230 x 72 x 74.7 mm - 9 x 3 x 3 inch  
1.3 kg - 2.8 lbs



The HR80, HR150 and HR200 manually removable extensions are delivered in a PELICASE filled with high density foam into which an imprint of the extensions is made. It provides a perfect fit for the transport or storage. The HR7 and its extension will work on almost all doors. The extensions are an option when buying the HR7 door-opener.

## ACCESSORIES - CLAIE DE PORTAGE POUR HR7



HR7 backpack rack	ref. CLE/HR7
colour	black
transport harness	grey / black nylon
adjustable straps	yes
transport handle	yes
material	black powder coated aluminium alloy
dimensions	595 x 435 x 125 mm - 23 x 17 x 5 inch
weight empty	8.3 kg - 18.3 lbs
weight loaded	24.9 kg - 55 lbs

The HR7 is delivered in a PELICASE transport case but it can be replaced by a backpack rack on demand. The LIBERVIT backpack rack is made of black powder coated aluminium alloy and has wide adjustable shoulder straps as well as an abdominal one to provide comfort and stability when carrying it. Each backpack rack has fasteners adapted to the tools it carries.

## ACCESSORIES - PLKIT/ HR7- HR7 plates for PVC doors

plates' case (PVC doors)	ref. PLKIT/HR7
delivered in transport case	yes ref VDT/PLKIT, case PELICASE
plates included	ref. PRL125/HR7, PRL180/HR7, PRL300/HR7
case dimensions	470 x 357 x 176 mm - 18.5 x 14 x 7 inch
weight empty	3.2 kg - 6.5 lbs
weight loaded	13.4 kg - 28 lbs



plates	ref. PRL125/HR7
dimensions	90 x 125 x 60 mm - 3.5 x 5 x 2.5 inch
plate weight	1.1 Kg - 2.6 lbs
quantity	2 plates

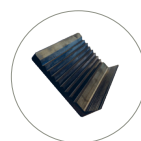

plates	PRL180/HR7
dimensions	90 x 180 x 70 mm - 3 x 7 x 2 inch
plate weight	1.6 kg - 3.5 lbs
quantity	2 plates

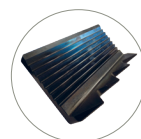

plates	ref. PRL300/HR7
dimensions	70 x 300 x 40 mm - 2 x 12 x 2 inch
plate weight	2.05 kg - 4.5 lbs
quantity	2 plates

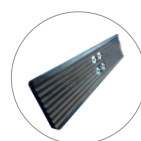

The special PVC doors plates are manually removable and are packed in a PELICASE. The PRL125/HR7 anti-slip with hook plate is placed between the door and the door frame to guarantee an extra grip for the jack while pushing. The PRL180/HR7 and the PRL300/HR7 have the same function with different dimensions. The PRL300/HR7 is mainly used with doors framed by decoration mouldings. The PLKIT/HR7 is an option when buying a HR7 hydraulic door-opener.

# VE70-L- high performance hydraulic door-openers

the VE70-L hydraulic door-opener opens heavy-armoured, inward-opening, multi-locks doors or outward-opening metal doors when equipped with the option T.



## VE70-L/KIT



The VE70-L hydraulic door-opener opens heavy-armoured, inward-opening, multi-locks doors or outward-opening metal doors when equipped with the option T. Silent, quick and easy to use, a heavy-armoured door can be opened in less than 20 seconds.

3 extensions complete the set. These accessories can be used when facing unusual situations like steps before a door. The upper bearing plate is fitted with a manually removable plate. The doors' opening is done progressively, without impact and in optimal silence whichever mode chosen: remote controlled or by actioning the control switch on the tool.

Rubber stoppers, placed at strategic points along the tool reduce the noise risk during transportation and whilst operating.

(\*tool not self-sufficient needs to be used with a hydraulic power unit or manual pump)





# VE70-L/KIT high performance door-opener and accessories

TECHNICAL CHARACTERISTICS		
VE70-L hydraulic jack set	ref. VE70-L/KIT	
high performance hydraulic door-opener thrust	ref. VE70-L 71 kN	
hydraulic jack stroke	522 mm - 20.5 inch	
hydraulic jack retracted	1130 mm - 44.5 inch	
hydraulic jack deployed	1650 mm - 65 inch	
upper support length	880 mm - 35 inch	
deployed upper support length	990 mm - 39 inch	
transport handle	yes	
upper support plate	yes (removable)	
door & ground plate support crampons	yes (removable)	
door & ground anti-noise plate sole	yes (removable)	
available colours	dark grey, black or olive green	
VE70-L dimensions	1130 x 300 x 135 mm - 45 x 12 x 5 inch	
VE70-L weight	16 kg - 35 lbs	
150 mm extension length	ref. R150 L 150 mm - 6 inch	
weight	1 kg - 2 lbs	
300 mm extension length	ref. R300 300 mm - 12 inch	
weight	1.8 kg - 4 lbs	
450 mm extension length	ref. R450 450 mm - 18 inch	
weight	2.5 kg - 5.5 lbs	
PELICASE® transport case	ref. VDT2 (LIBERVIT BLACKline)	réf. VLD2 (LIBERVIT Défense)
available colours	black	olive green
case dimensions	1350 x 405 x 170 mm - 53 x 16 x 7 inch	1366 x 419 x 170 mm - 53 x 16 x 7 inch
weight empty	10.7 kg - 23.5 lbs	10.5 kg - 23 lbs
case weight loaded	32 kg - 70.5 lbs	31.8 kg - 70 lbs



upper support plate

carbon upper support



door & ground anti-noise plate with SGI sole



door & ground bearing plate with crampons

locking button

hydraulic jack

service handle

hose coupling



PELICASE transport case 

**LIBERVIT**

# RETRACTED UPPER SUPPORT HEIGHT

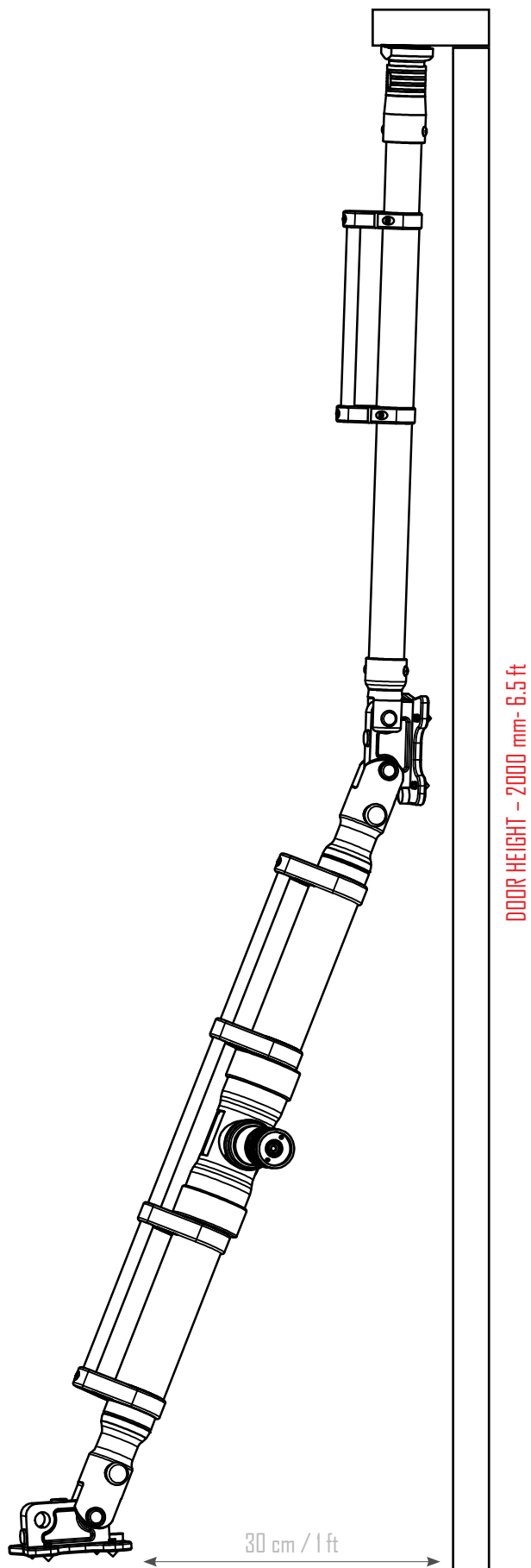

# DEPLOYED UPPER SUPPORT HEIGHT

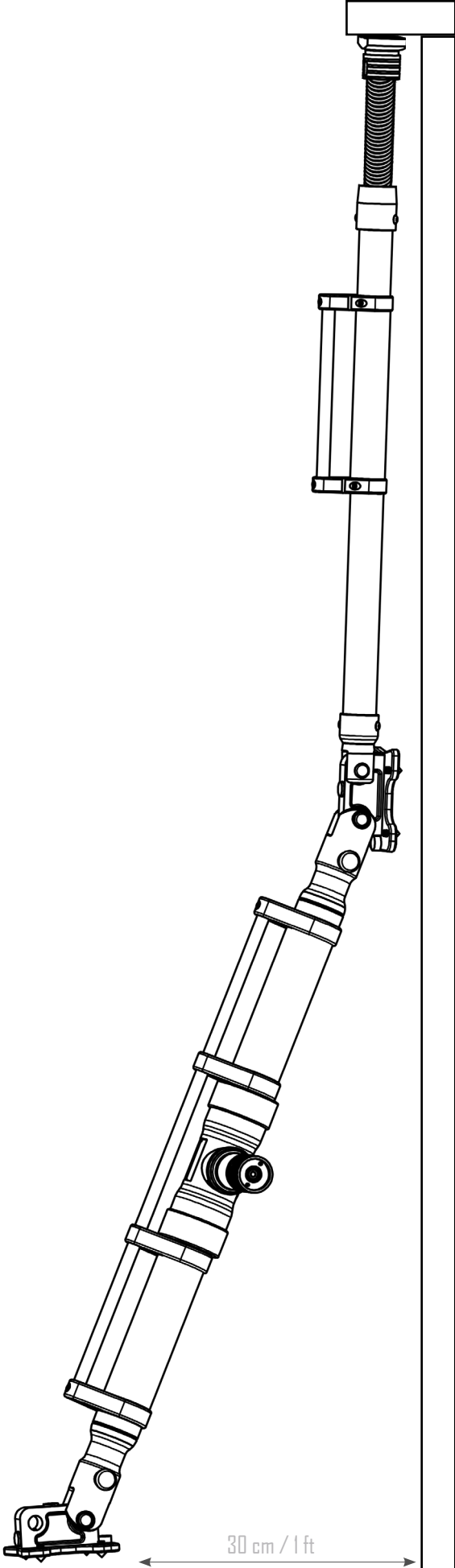

DOOR HEIGHT - 2110 mm - 7 ft

30 cm / 1 ft

**LIBERVIT**

# VE70L JACK'S ACCESSORIES



R150 extension  
R300 extension  
R450 extension

ref. R150, L 150 mm - 6 inch  
ref. R300, L 300 mm - 12 inch  
ref. R450, L 450 mm - 18 inch

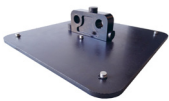

SGS1 small plate  
anti-slip crampons  
dimensions  
weight

ref. SGS1  
qty 6  
300 x 300 x 8 mm - 12 x 12 x 0.5 inch  
6.4 kg - 14 lbs

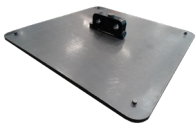

SGS2 large plate  
anti-slip crampons  
dimensions  
weight

ref. SGS2  
qty 6  
450 x 450 x 8 mm - 18 x 18 x 0.5 inch  
13.5 kg - 30 lbs



OMEGA anti-slip hooked bearing plate  
dimensions  
weight  
VE70-L jack adaptable

ref. OMEGA  
70 x 75 x 64 mm - 2.7 x 3 x 2.5 inch  
765 g - 1.6 lbs  
from July 2010



ASC/594 short bearing plate  
size  
material  
dimensions  
weight  
VE70-L jack adaptable

ref. ASC/594  
129 mm - 5 inch shorter than VE70-L bearing plate  
carbon fiber  
791 x 103 mm - 31 x 4 inch  
2.4 kg - 5 lbs  
from July 2010



KIT/ASO accessories in Pelicase<sup>®</sup>  
includes:  
short bearing plate  
flange axis  
short plate  
anti-slip hooked bearing plate  
PELICASE<sup>®</sup> transport case  
case dimensions  
weight empty

ref. KIT/ASO  
ref. ASC/594  
ref. VE70-L/EU-019  
ref. SGS1  
ref. OMEGA  
ref. VDT/ASO  
960 x 430 x 160 mm - 4 x 1.5 x 6 inch  
7.9 kg - 4 lbs

# VE70L JACK'S ACCESSORIES



optionT bearing point for outward opening metal doors

reference	optionT
hit pad	yes
dimensions	284 x 120 mm - 11 x 5 inch
weight	3.2 kg - 7 lbs
VE70-L jack adaptable	from July 2010
delivered in solid transport case	yes



SIG anti-noise sole

reference	SIG
dimensions	148 x 118 x 10 mm - 5 x 4 x 0.3 inch
weight	250 g - 9 oz
available colours	dark grey or olive green
delivered by	ref. SIG/5



THORN perforating spur

reference	THORN
dimensions	149 x 120 x 103 mm - 6 x 5 x 4 inch
weight	1.8 kg - 4 lbs
VE70-L jack adaptable	from July 2010
delivered in solid transport case	yes



VE70-L/C crampons

reference	VE70-L/C
crampon dimensions	Ø 148 x 22 mm - Ø 6 x 0.5 inch
crampon weight	9 g - 0.3 oz
circlips & crampons	qty 4 per bag



sharpening station

reference	TOURET/VE70/EU-015
turntable supply voltage	220 Volts
grinding wheel dimensions	Ø 150 x 20 x 32 mm - Ø 6 x 0.8 x 1.5 inch
station dimension	350 x 280 x 230 mm - 14 x 11 x 9 inch
weight	10.95 kg - 24 lbs



transport bag

reference	ST/VE70-L
dimensions	1150 x 350 x 150 mm - 45 x 14 x 6 inch
empty bag weight	1.5 kg - 3 lbs



PELICASE<sup>®</sup> transport case

reference	ref. VDT2
dimensions	1350 x 405 x 155 mm - 53 x 16 x 6 inch
weight empty	11.8 kg - 26 lbs

# EX50- anti-panic doors hydraulic door-opener

used to open single or multi-points anti-panic doors



## EX50



Designed to open single or multi-points anti-panic doors the EX50 is placed at the horizontal on a door. Once in place, activate the tool with the contactor on the service handle or with a remote control until the jack retracts and squashes the door. The NPB lever is used to ease the EX50 plates positioning. (\*tool not self-sufficient needs to be used with a hydraulic power unit or manual pump)





# EX50- anti-panic doors hydraulic door-opener

TECHNICAL CHARACTERISTICS		
anti-panic doors hydraulic door-opener	ref. EX50	
tractive effort	50kN	
jack's stroke	252 mm - 10 inch	
retracted jack length	773.5 mm - 30.5 inch	
deployed jack length	1025 mm - 40 inch	
short angle	qty 1	
long angle	qty 1	
handle	yes	
available colours	dark grey, black or olive green	
dimensions	1025 x 254 x 200 mm - 40 x 10 x 8 inch	
weight	9.7 kg - 21 lbs	
lever	ref. NP8	
telescopic	yes	
material	black treated steel	
length	370 mm - 1.5 ft	
handle diameter	Ø 20 mm - Ø 0.7 inch	
handle protection	electrical shocks' protective coating	
available colours	dark grey or olive green	
dimensions	370 x 35 mm - 14 x 1 inch	
weight	1 kg - 2.2 lbs	
PELICASE® transport case	ref. VDT/EX50 (LIBERVIT BLACKline)	ref. VLD/EX50 (LIBERVIT Défense)
Available colours	black	olive green
case dimensions	969 x 406 x 155 mm - 38 x 16 x 6 inch	1011 x 419 x 170 mm - 40 x 16 x 7 inch
weight empty	7.8 kg - 17 lbs	8.9 kg - 23 lbs
weight loaded	19.5 kg - 43 lbs	20.6 kg - 45 lbs

## ON OPTION -EX50 JACK ACCESSORIES



protection cap  
colour  
dimensions  
weight

ref. BF  
noir  
40 mm x Ø60 mm - 1.5 inch x Ø2.5 inch  
60 g - 0.13 lbs

The short angle must always be placed by the anti-panic door lock.



If positioning the EX50 gets difficult use the NPB lever to create a gap.



valise de transport PELICASE 

**LIBERVIT**

# LASER RANGEFINDER & TAPE MEASURE

The laser rangefinder and the tape measure are useful to measure distances before positioning the DOOR RAIDER or the HR7.



## LASER METER 30 - L3M



The LASER METER 30 laser rangefinder is useful to calculate the right distance between the ground and the door upper frame or to measure the door's length before setting the VE70L or the HR7 door-openers.

The L3M self-locking magnetic tape measure is useful to calculate the right distance between the ground and the door upper frame or to measure the door's length before setting the VE70L or the HR7 door-openers.



TECHNICAL CHARACTERISTICS	
laser rangefinder	ref. LASER METER 30
batteries	2 AAA batteries included
measure accuracy	Typ. +/- 1/16-in (1.5 mm- 0.06 inch)
range	up to 30 m - 100 ft.
protection sleeve	yes
weight	100 g - 0.22 lbs
dimensions	40 x 100 x 25 mm - 1.5 x 4 x 1 inch

TECHNICAL CHARACTERISTICS	
Tape measure	ref. L3M
Tape length	3 m - 10 ft
Tape width	16 mm - 0.5 inch
magnetic	yes
self-locking	yes
weight	11 g - 0.5 oz
dimensions	70 x 60 x 30 mm - 3 x 2.5 x 1 inch

# ENTRY HYDRAULIC UNITS

All our hydraulic door-openers are compatible with our hoses and hydraulic units and manual pumps.





DP55 hydraulic units



DP71 hydraulic units



HR7 hydraulic units



VE70-L hydraulic units



EX50 hydraulic units

# OP55 hydraulic units' selection

the OP55 hydraulic door-opener can be power supplied by all LIBERVIT hydraulic units and manual pumps.





## SNIPER I

the SNIPER I unit includes:

- a B.A.S. superlight hydraulic unit
- a DP55 door-opener with its ST/DP55 transport bag
- DP55 fixing harness on B.A.S. superlight



## OPH55

the OPH55 unit includes:

- a GHP hydraulic unit
- a DP55 door-opener with its ST/DP55 transport bag



## OP55P

the OP55P unit includes:

- a POWERCASE hydraulic unit (integrated 3m hydraulic hose)
- a DP55 door-opener with its ST/DP55 transport bag



## OPM55

the OPM55 includes:

- a PML10 hydraulic manual pump
- a LF3 hydraulic hose
- a NPB lever
- a DP55 door-opener (without its transport bag)
- a soft back-rack EBP/OPM55



# OP71 hydraulic units' selection

the OP71 hydraulic door-opener can be power supplied by all LIBERVIT hydraulic units and manual pumps.





## SNIPER II

The SNIPER II unit includes:

- a B.A.S. superlight hydraulic unit
- a DP71 door-opener with its ST/DP7 transport bag
- DP71 fixing harness on B.A.S. superlight



## OPH71

the OPH71 unit includes:

- a GHP hydraulic unit
- a DP71 door-opener with its ST/DP7 transport bag



## OPP71

the OPP71 unit includes:

- a POWERCASE hydraulic unit (integrated 3m hydraulic hose)
- a DP71 door-opener with its ST/DP7 transport bag



## OPM71

the OPM71 includes:

- a PML10 hydraulic manual pump
- a LF3 hydraulic hose
- a NPB lever
- a DP71 door-opener (without its transport bag)
- a soft back-rack EBP/OPM71

# HR7 hydraulic units' selection

The HR7 hydraulic door-opener can be power supplied by all LIBERVIT hydraulic units and manual pumps.





## BHR7

The BHR7 unit includes:

- a B.A.S. superlight hydraulic unit
- a LF3 hydraulic hose
- a complete HR7 door-opener in PELICASE



## GHR7

the GHR7 unit includes:

- a GHP hydraulic unit
- a LF3 hydraulic hose
- a complete HR7 door-opener in PELICASE



## PHR7

the PHR7 unit includes:

- a POWERCASE hydraulic unit (integrated 3m hydraulic hose)
- a complete HR7 door-opener in PELICASE



## MHR7

the MHR7 hydraulic unit includes:

- a PML10 hydraulic manual pump
- a LF3 hydraulic hose
- a complete HR7 door-opener in PELICASE

# VE70-L hydraulic units' selection

The VE70-L high performance hydraulic door-opener can be power supplied by all LIBERVIT hydraulic units and manual pumps.





## DOOR RAIDER light B

the DOOR RAIDER light B unit includes:

- a B.A.S. superlight hydraulic unit and its PELICASE
- a VE70-L jack, extensions in their PELICASE DOOR RAIDER light



## DOOR RAIDER light

the DOOR RAIDER light unit includes:

- a GHP hydraulic unit and its PELICASE
- a VE70-L jack, extensions in their PELICASE



## DOOR RAIDER light P

DOOR RAIDER light P:

the DOOR RAIDER light P unit includes:

- a POWERCASE hydraulic unit (integrated 3m hydraulic hose)
- a VE70-L jack, extensions in their PELICASE



## DOOR RAIDER light M

DOOR RAIDER light M

the DOOR RAIDER light M unit includes:

- a PML30 hydraulic pump and its PELICASE
- a LF3 hydraulic hose
- a VE70-L jack, extensions in their PELICASE

# EX50 hydraulic units' selection

the EX50 anti-panic door opener can be power supplied by all LIBERVIT hydraulic units and manual pumps.





## BEX50

the BEX50 unit includes:

- a B.A.S. superlight hydraulic unit and its PELICASE
- an EX50 hydraulic door opener, its lever and their PELICASE



## GEX50

the GEX50 unit includes:

- a GHP hydraulic unit and its PELICASE
- an EX50 hydraulic door opener, its lever and their PELICASE



## PEX50

the PEX50 unit includes:

- a POWERCASE hydraulic unit (integrated 3m hydraulic hose)
- an EX50 hydraulic door opener, its lever and their PELICASE



## MEX50

the MEX50 unit includes:

- a PML30 hydraulic pump and its PELICASE
- a LF3 hydraulic hose
- an EX50 hydraulic door opener, its lever and their PELICASE



# HYDRAULIC UNITS & MANUAL PUMP

all our tools can be power supplied by all our hydraulic units and manual pumps.





GHP: portable hydraulic unit



POWERCASE: hydraulic unit in a case



B.A.S. superlight: portable and connected light hydraulic unit



PML10 & PML30: hydraulic manual pumps

# B.A.S. superlight – hydraulic unit

power supply all the LIBERVIT hydraulic tools from the BLACKline and Défense ranges.



## B.A.S. superlight



Compact, light and silent the B.A.S. hydraulic unit power supplies all the LIBERVIT hydraulic tools from the BLACKline and Défense ranges.

Transportable on the back, with a shoulder strap or by hand you will be able to evolve in difficult access area while keeping your hands free.

A dashboard protected by a removable flap provides access to the start-up switch as well as to the battery charge status indicator.

The B.A.S hydraulic unit has an integrated 1.5 m hydraulic hose and a 48V lithium battery offering 120 minutes of working time to a tool.

Functions and accessories within the next pages.



# TECHNICAL CHARACTERISTICS

TECHNICAL CHARACTERISTICS	
hydraulic unit	ref. B.A.S. superlight
service pressure	300 bar
tank capacity	1.24 L - 42 fl oz
outer shell	soft Cordura®
fermetures	YKK® water repellent zipper
IP index	IP64
extreme condition sleeve	IP65 (on option)
available colours	dark grey or olive green
modular portage	back / hand / shoulder strap
molle® system	yes
L side removable pocket	qty 1, ref. PA1/BSL
utilisation, transport, storage	T360° multi-position technology
lifting ring	at the unit back to lifft, air lift , lever, hang
integrated hose	1.50 m - 5 ft
hose casing	yes
decibels	48 dB*
power supply	qty 1, LIBERVIT 48 V Lithium battery, ref. BI-ION48
autonomy	120 minutes of tool action**
battery removal	manual
maximum charge time	35 min for 100% charge
battery charge indicator	yes
auto-shutdown	yes, after 4 hours non-use (auto-shutdown adjustable & can be disabled)
LIBERVIT automatic charger	qty 1, réf. CB-ION48
convertible hand radio remote	qty 1, sleeve / molle® system, ref. cMrf
power cable length	3 m - 10 ft
radio remote range	30 m - 99 ft
connected unit	LIBERVIT Connected app on Google Play & Huawei store
dimensions	230 x 280 x 400 mm - 9 x 11 x 15.5 inch
weight	10.7 kg - 23.5 lbs***

\* test done at a 5 m distance

\*\* test done at a 150 bar average pressure

\*\*\* ready to use without portage means

ACCESSORIES	
interactive radio remote wristband	on option, ref. BRI
extreme conditions sleeve	on option, ref. HCE/BSL
extra removable pocket	on option, left side (L) : ref. PA1/BSL or right side (R) : ref. PA2/BSL
magnetic kit	on option, ref. KM/BSL
hook kit	on option, ref. KC/BSL
peripherals transport bag	on option, ref. STP/BSL pour handle, shoulder strap, straps, battery charger, radio remotes
transport bag	on option, ref. VDT/BSL

The B.A.S. superlight unit, its charger and radio remote can be packed in a solid case.

PELICASE® tarsnport case	ref. VDT/BSL(LIBERVIT BLACKline)	ref. VLD/BSL(LIBERVIT Défense)
available colours	black	olive green
telescopic handle	yes	yes
wheels	yes	yes
dimensions	630 x 510 x 300 mm - 25 x 20 x 12 inch	795 x 518 x 310 mm - 31 x 20 x 12 inch
weight empty	10.5 kg - 23 lbs	13 kg - 28 lbs
case loaded	24.5 kg - 54 lbs	27 kg - 59 lbs

# HYDRAULIC TOOLS POWER SUPPLY

The B.A.S. superlight power supplies all the tools from the LIBERVIT BLACKline and Défense ranges. We designed this unit with in mind the fact that we wanted it to power supply all our latest tools but also all the LIBERVIT tools manufactured these last 20 years.



spreaders



cutters



jacks



EX50 door opener



OP series  
door opener



mid range HR7  
door opener



VE70-L  
high performance  
door opener

**LIBERVIT**

# TECHNICAL DATAS



A dashboard protected by a removable flap provides access to the start-up switch as well as to the battery charge status indicator.



The B.A.S. hydraulic unit has a 48V lithium battery, giving an average autonomy of 120 minutes in tool action.



The hydraulic unit is supplied as standard with a hand remote control, wired / wireless convertible, usable at 3 m distance in wired configuration and at 30m distance in wireless configuration.



The use of wired or radio remote control makes it possible, in the event of a trapped door or an armed assailant, to activate the hydraulic power unit while maintaining an essential safety distance. The remote control has a battery charge status indicator. They have long-lasting rechargeable batteries and can be recharged by simply connecting the remote control to the hydraulic unit without requiring a mains supply.



A 1.5 meters hydraulic hose is permanently stored in a dedicated compartment, just open it to extract the hose. The compartment has 2 openings giving you the choice to extract it from left or right.



To protect the battery and increase its autonomy we have fitted the B.A.S superlight unit with an auto-shutdown technology. The auto-shutdown kicks in after 4 hours of non-use. The auto-shutdown can be disabled through the LIBERVIT app and it can be set to a 1 to 8 hours period.



With the T360 technology developed by LIBERVIT, the B.A.S. superlight hydraulic unit can be used and stored in all positions, while retaining all of its performance.



Removable and washable the B.A.S superlight hydraulic power unit' outer shell is made of multi-layered padded Cordura (1100 Den) and is IP64. It is also fitted with water-repellent zippers and anti-noise partitions.



A lifting ring at the back of the unit offers a 100% reliable anchor point to lift, air lift and hang..



The integrated wire charges: the lithium battery via the charger, the remote-control battery.



The B.A.S superlight hydraulic power unit does not exceed the 45 dB at 5 m.



The LIBERVIT connected application available on the Google Play & Huawei stores will enable you to diagnose your power unit and will also indicate: the battery charge status, the number of charges /discharges already done, the oil level, the engine running status, the radio remotes functioning as well as the battery charger, the tool's effort produced and many more useful information.



# BI-ION 48 battery's ballistic tests report



As we aim to provide quality and safety for our users, we've conducted some ballistic impacts tests on our LIBERVIT B.A.S. superlight powered by a Lithium battery ref: BI-ION48. This exhaustive report will give you information on the pros & cons of our batteries. We will keep working hard to improve our equipment and maintain the quality you already know as well as increasing as much as possible our users' safety.

Ballistic impacts tests executed with the arms and calibers listed below:



HK G36  
Fusil automatique

223 Remington  
Cal. 5.56 OTAN



HK417  
Fusil automatique

308 Winchester  
Cal. 7.62 OTAN

## OBJECTIVE :

Point out potentially dangerous risks, momentary and/or persistent: (explosion/projection/flammable).

## TESTS :

1- Automatic rifle HK417: cal 7.62 OTAN, 308 Winchester, 50 m/164 ft shot :

Instant reaction: white smoke, sparks.

Delayed reaction: after +/- 15 mn, no flame, no flow.

Battery visual aspect: perforated from side to side.

2- Automatic rifle M4: cal 5.56 OTAN, 223 Remington, 50 m/164 ft shot :

Instant reaction: white smoke, no sparks.

Delayed reaction: after +/- 15 mn, no flame, no flow.

Battery visual aspect: perforated from side to side.

3- automatic rifle HK G36: cal 5.56 OTAN, 223 Remington and HK417: cal 7.62 OTAN, 308 Winchester 5 m shot:

Instant reaction: white smoke, no sparks.

Delayed reaction: after +/- 15mn, : no flame, no flow

Battery visual aspect: perforated from side to side



## CONCLUSION :

The different ballistic tests executed gave us the opportunity to find out the damages and their consequences done to a LIBERVIT BI-ION48 battery when shot at. All the batteries have been perforated from side to side generating white smoke but no flame and no flow and no explosion has been witnessed.

**THE USE OF LIBERVIT POWER UNITS IS EXPLOSION AND BURST RISK FREE UNLIKE EQUIPMENTS USING AIR COMPRESSED BOTTLES.**

# LIBERVIT Connected

complete hydraulic unit diagnosis via the LIBERVIT connected app.

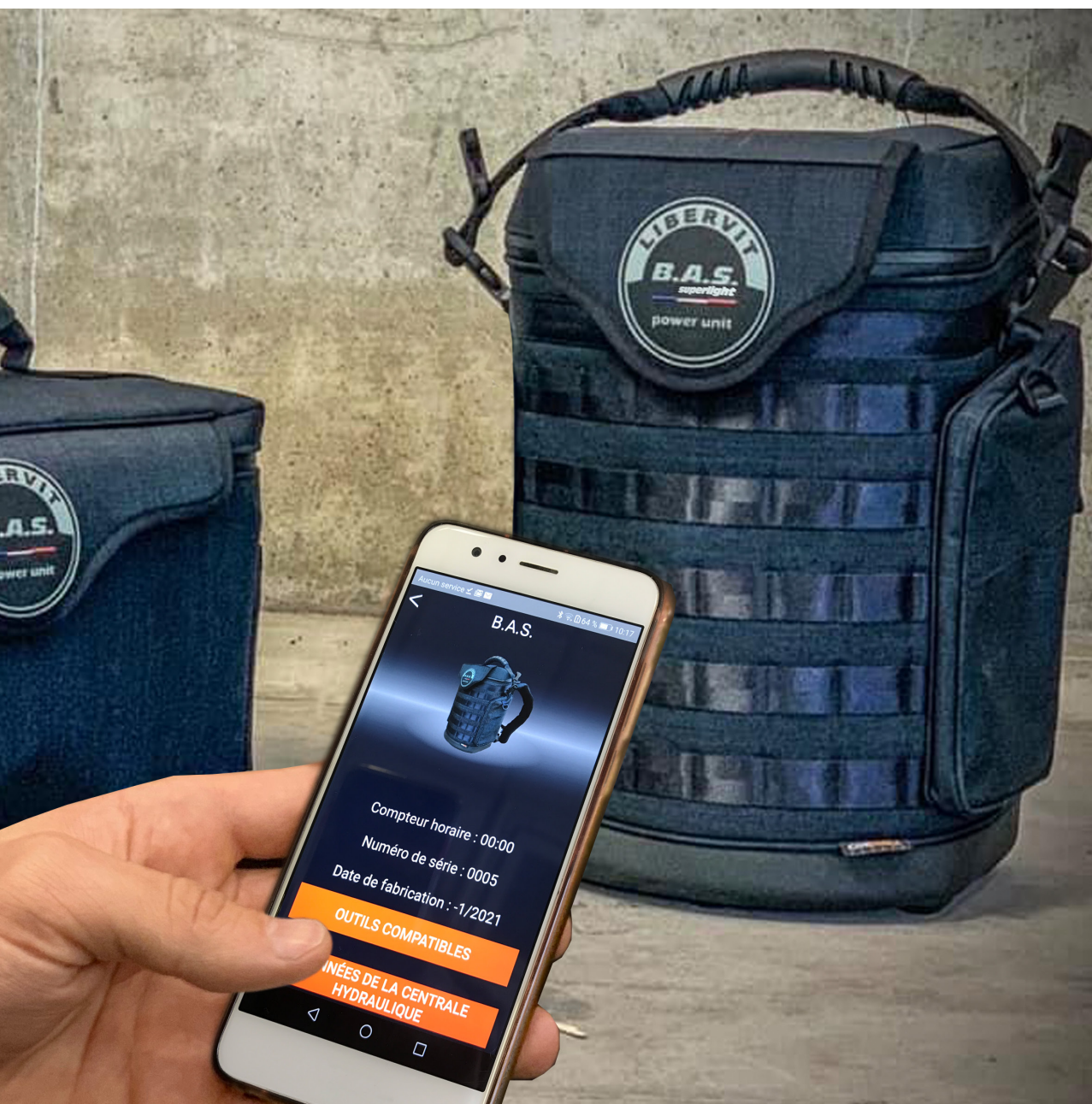



Bluetooth

## LIBERVIT Connected



To ease as much as possible our units' preventive maintenance, the B.A.S. superlight unit is delivered in series with a receiving and transmitting data system that all users can access on their smart phone to perform a complete diagnosis of their equipment. The Application LIBERVIT connected can be downloaded from the Google or Huawei store.

The diagnostic indicates:

The battery charge status

The hydraulic oil level

The engine condition

The hydraulic pressure

The radio remotes condition

The battery charger condition

The tool's effort (in use with the unit)

And much more

You will be able to send an email directly from your phone to our technical department with the diagnosis. Our technicians will be able to read the data and act accordingly if a maintenance or repair is needed and help you if it is possible through our Hotline.



> AFTER SALES SERVICE : [aftersales@libervit.com](mailto:aftersales@libervit.com)



AFTER-SALES  
TOLL FREE

0 805 385 123

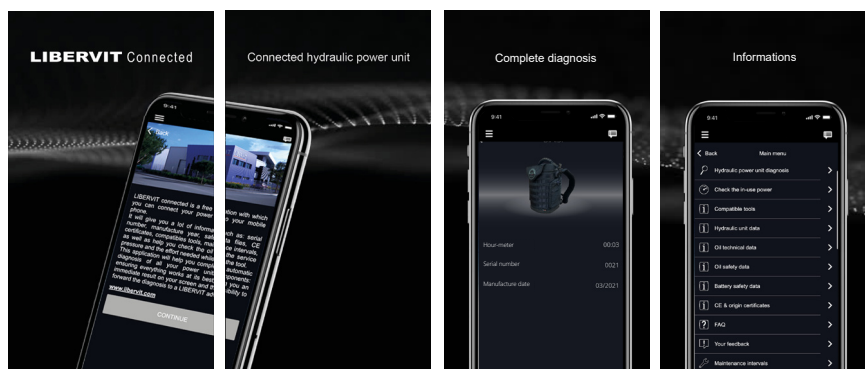

# INTERECTIVE RADIO REMOTE WRISTBAND

on option, the interactive radio remote wristband activates the B.A.S. hydraulic power unit from a distance.





## BRI

The interactive radio remote wristband activates the B.A.S. hydraulic power unit from a distance (maximum range: 30 m), the tool's effort in action in real time is also visible on the screen.

Its waterproof (IP64) touch screen indicates the radio signal, the battery level (10h autonomy in use), the date and time. The wristband also benefits from a red LED (added light - ON or OFF) and a USB-C port to charge it.

You can check whether the auto-shutdown is activated or not.

Activate or disable the auto-shutdown from the LIBERVIT connected App.

### TECHNICAL CHARACTERISTICS

Interactive radio remote wristband	ref. BRI
Radio communication :	with the B.A.S. superlight unit range 30 m
datas :	real time tool's effort in % radio signal level battery level (BRI + BAS superlight) ASD (unit Auto-shutdown) activated / disabled hours/ date
functions :	unit activation visualization of the tool's power used in % red LED USB-C port to charge the BRI
battery	LiPo 3.7 V - autonomie 10h
waterproof	yes, IP64
wristband	50mm adjustable strap with Velcro
dimensions	90 x 30 mm - 3.5 x 1 inch
weight	80 g - 3 oz

## B.A.S. superlight power unit's accessories

on option are available some accessories for the  
B.A.S. superlight





#### PERIPHERALS TRANSPORT BAG

Ref: STP/BSL

The B.A.S. superlight peripherals can be protected and stored in a transport bag: handle, shoulder straps, strap, backrest, battery charger, radio remotes and an extra battery.



#### MAGNETIC KIT

Ref: KM/BSL

With the magnetic kit you can free yourself from the unit weight and plate it against any metallic surface (vehicle frame, lorries, etc.)



#### HOOK KIT

Ref: KC/BSL

To hang the B.A.S. superlight unit when it cannot be left on the floor.



#### EXTREME CONDITION SLEEVE

Ref: HCE/BSL

It will protect your B.A.S. superlight unit from extreme weather conditions such as heavy rain, sandstorm, etc.



#### PELICASE® TRANSPORT CASE

Ref: VDT/BSL (LIBERVIT BLACKline) or ref: VDT/BSL (LIBERVIT Défense)

The B.A.S. superlight unit, its battery charger and the radio remotes can be packed in a in a waterproof case. The VDT/BAS is fitted with a high density black foam in which an imprint of the tool has been made to keep it secure during transport or storage.

We use the PELICASE® brand for its quality and reliability. Our cases all meet the military and air transport norms, have wheels and a foldable handle.





# GHP- hydraulic unit

power supplies all the LIBERVIT BLACKline and Defense ranges' hydraulic tools.





## GHP

hand remote control



power cable



foot pedal remote control

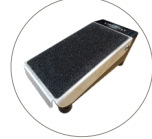

The GHP hydroelectric power unit is designed as a backpack for easier transportation, giving you the freedom of movements to progress in harsh environment. The power unit is equipped with a Lithium battery that can be changed manually in a couple of seconds; it is also equipped with a battery charge indicator flashing light : replace / charge battery. The GHP hydraulic unit can power supply all BLACKline & Defense range hydraulic tools. Both radio remotes can be used as a wireless remote (30m range) or as a wired command control unit (5m range).



# TECHNICAL CHARACTERISTICS

## TECHNICAL CHARACTERISTICS

power unit	ref. GHP
service pressure	300 bar
tank capacity	1.7 L - 60 fl oz
outer shell	polyester fibres protective hood on solid frame
available colours	dark grey or olive green
transport	back / handheld
integrated hose	1.50 m - 5 ft
decibel	66 dB*
power supply	batterie Lithium 12 Volts, réf. BLFP
autonomy	45 minutes of tool action
battery removal	manual
maximum charge time	90 min for 100% charge
charge indicator	yes
battery charger	yes
convertible hand radio remote	qty 1, with sleeve
foot pedal radio remote	qty 1
power cable length	5 m - 16.5 ft
radio remotes range	30 m - 99 ft
dimensions	500 x 240 x 260 mm - 19 x 9.5 x 10 inch
weight	16 kg - 35 lbs**
* tests done at a 5 m/ 16.5 ft distance	
** ready to use	

## ACCESSORIES

The GHP unit, its battery charger and the radio remotes can be packed in a waterproof case. The VDT1 case is lined with high-density black foam in which an imprint of the tool has been made to guarantee its perfect fit and an optimal protection at all time. We chose the PELICASE brand as a guarantee for both quality & long life. All our cases meet military & air transport standards. They are equipped with wheels and a removable carrying handle. The VDT1 is an option when buying a GHP unit.

PELICASE® transport case	réf. VDT1 (LIBERVIT BLACKline)	réf. VLD/GHP(LIBERVIT Défense)
available colours	black	olive green
telescopic handle	yes	yes
wheels	yes	yes
dimensions	800 x 520 x 300 mm - 31 x 21 x 11 inch	795 x 518 x 310 mm - 31 x 20 x 12 inch
weight empty	12.5 kg - 27.5 lbs	13 kg - 28 lbs
weight loaded	32.5 kg - 72 lbs	33 kg - 73 lbs





# POWERCASE- hydraulic unit

this suitcase unit powers all the LIBERVIT BLACKline and Défense ranges' hydraulic tools.



## POWERCASE



hand remote control



power cable



foot pedal remote control



At the request of some special intervention groups, we have transformed a PELICASE into a power unit. All the necessary components to supply our BLACKline range hydraulic tools have been fitted and assembled inside the case. Its performance are identical to that of the GHP unit. In the case are found: the hydraulic unit, a 3m long hose, a lithium battery and a battery charger.

On its front is a quick coupling to connect the hydraulic hose or the battery charger.



# TECHNICAL CHARACTERISTICS

## TECHNICAL CHARACTERISTICS

power unit	ref. POWERCASE
service pressure	300 bar
tank capacity	1.7 L - 60 fl oz
outer shell	PELICASE® transport case
telescopic handle	yes, removable
transport wheels	yes
available colours	black (LIBERVIT BLACKline) or olive green (LIBERVIT Défense)
transport	by hand
hydraulic hose	in case, 3 m - 9.8 ft , réf. LF3
decibel	60 dB*
power supply	12V lithium battery, réf. BLFP
autonomy	45 minutes of tool action
battery removal	manuel
maximum charge time	90 min for 100% charge
charge indicator	yes
battery charger	yes
convertible hand radio remote	qty 1, with sleeve
foot pedal radio remote	qty 1
power cable length	5 m - 16.5 ft
radio remotes range	30 m - 99 ft
dimensions	559 x 351 x 229 mm - 22 x 14 x 9 inch
weight	24 kg - 53 lbs**

\* test done at a 5 m/ 16.5 ft distance

\*\* readu to use



